



FSP201 Module

Quick Start Guide 1000-5133

Rev. 1.0

March 2026

**CONFIDENTIAL AND PROPRIETARY
UNAUTHORIZED REPRODUCTION PROHIBITED**

Disclaimer and Proprietary Information Notice

The information contained in this document does not represent a commitment on any part by Ceva®, Inc., or its subsidiaries (collectively, "Ceva "). Ceva makes no warranty of any kind with regard to this material, including, but not limited to implied warranties of merchantability and fitness for a particular purpose whether arising out of law, custom, conduct, or otherwise.

Additionally, Ceva assumes no responsibility for any errors or omissions contained herein, and assumes no liability for special, direct, indirect, or consequential damage, losses, costs, charges, claims, demands, fees, or expenses, of any nature or kind, which are incurred in connection with the furnishing, performance, or use of this material.

This document contains proprietary information, which is protected by U.S. and international copyright laws. All rights reserved. No part of this document may be reproduced, photocopied, or translated into another language without the prior written consent of Ceva. All product names are registered trademarks of Ceva®, Inc. and/or its subsidiaries, or, of its applicable suppliers if so stated.

Support

Ceva® makes great efforts to provide a user -friendly software and hardware development environment. Along with this, Ceva provides comprehensive documentation, enabling users to learn and develop applications on their own. Due to the complexities involved in the development of DSP applications that might be beyond the scope of the documentation, an online Technical Support Service has been established. This service includes useful tips and provides fast and efficient help, assisting users to quickly resolve development problems.

How to Get Technical Support:

- **FAQs:** Visit our website <http://www.Ceva-dsp.com> or your company's protected page on the Ceva website for the latest answers to frequently asked questions.
- **Application Notes:** Visit our website <http://www.Ceva-dsp.com> or your company's protected page on the Ceva website for the latest application notes.
- **Email:** Use the Ceva central support email address Ceva-support@Ceva-dsp.com. Your email will be forwarded automatically to the relevant support engineers and tools developers who will provide you with the most professional support to help you resolve any problem.
- **License Keys:** Refer any license key requests or problems to sdtkeys@Ceva-dsp.com. For SDT license keys installation information, see the *SDT Installation and Licensing Scheme Guide*.

Email: Ceva-support@Ceva-dsp.com

Visit us at: www.Ceva-dsp.com

Table of Contents

1. INTRODUCTION	7
1.1 Scope.....	7
1.2 Audience	7
1.3 Related Documents	7
1.4 Overview	7
2. HARDWARE	8
2.1 Introduction	8
2.2 Connections	8
2.2.1 Host Interface Mode Selection.....	9
2.2.2 Module Pinout	9
2.3 Mechanical.....	10
2.3.1 Sensor Orientation	10
2.3.2 Module Dimensions.....	10
2.3.3 Module Recommended PCB Footprint.....	11
3. GLOSSARY.....	12

List of Figures

Figure 2-1: FSP201 Module with BMI088	8
Figure 2-2: FSP201 Module Orientation	10
Figure 2-3: FSP201 Module Dimensions (Component side)	10

List of Tables

Table 2-1: Host Interface Selection	9
Table 2-2: Module Pinout	9
Table 2-3: FSP201 Module PCB Footprint.....	11
Table 3-1: Acronyms	12

1. Introduction

1.1 Scope

This document describes the features and operation of the FSP201 Module.

1.2 Audience

This document is intended for anyone who wants to evaluate the FSP201.

1.3 Related Documents

The following documents are related to the information in this document:

1. *1000-4819 FSP201 Datasheet, Ceva, Inc.*
2. *1000-3625 SH-2 Reference Manual, Ceva, Inc.*
3. *1000-4906 FSP201 Simple Calibration User Guide, Ceva, Inc.*
4. *1000-3535 Sensor Hub Transport Protocol*
5. *1000-4868 Schematic, FSP201 Module*

1.4 Overview

The FSP201 is a 6-axis IMU processor, integrating Ceva's high - performance sensor hub software stack, to provide heading and orientation outputs. When connected to one of several supported sensors, it performs all the accelerometer and gyroscope sensor fusion processing necessary to produce stable and accurate heading and orientation outputs. This document is intended to provide information about the FSP201 Module to facilitate customer evaluation.

2. Hardware

2.1 Introduction

The FSP201 Module includes the FSP201 sensor hub processor with either the Bosch BMI088 or ST Micro LSM6DSR 6-axis sensor.

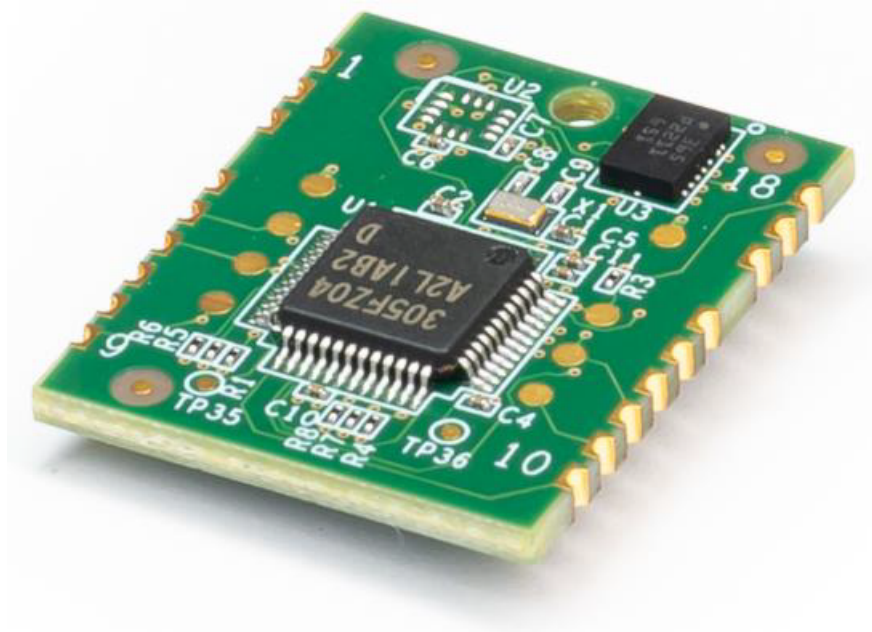

Figure 2-1: FSP201 Module with BMI088

2.2 Connections

The FSP201 communicates with the host system over a UART or I2C interface. The UART interface can be either in UART-RVC mode or in UART-SHTP mode. The I2C interface is in I2C over SHTP mode.

In UART-SHTP or I2C-SHTP modes, the FSP201 uses the Sensor Hub Transport Protocol (SHTP) to communicate with a system or application processor. The SHTP protocol is documented in the Sensor Hub Transport Protocol [4], allowing a customer to potentially develop their own host software if they choose to do so.

In UART-RVC mode, the FSP201 transmits heading and sensor information at 100Hz.

The host protocol selection is made with the PS0 and PS1 signals. The module's default configuration is UART-RVC mode.

2.2.1 Host Interface Mode Selection

The module can be configured for any of the following host interface options. The PS pins are set for UART-RVC mode by default. To select a different interface mode just terminate the PS per the table below. For example, to select I2C-SHTP mode you will need to pull PS0 pin low. Interface selection is done at startup time, please see the FSP201 Datasheet (1) for more information.

PS1	PS0	Mode
0	0	I2C over SHTP
0	1	UART-RVC *
1	0	UART over SHTP
1	1	reserved

*module's default

Table 2-1: Host Interface Selection

2.2.2 Module Pinout

Pin	Signal Name	Mode	Description	Module Connections
1	Vdd	Power	Power	Connect to 1.6V-3.6V
2	GND	Power	Ground	Ground
3	NC		not connected	leave floating
4	NC		not connected	leave floating
5	H_INTN_RED	Output	Host interface interrupt or calibration status	
6	H_BOOTN	Input	Bootloader select	
7	H_PS1	Input	Host interface protocol select 1	Pulled high 10k ohm to Vdd
8	GND	Power	reserved, do not connect	Ground
9	H_PS0_WAKEN	Input	Host interface protocol select 0, wake	Pulled low 10k ohm to ground
10	RSV	Reserved	reserved, do not connect	leave floating
11	H_SDA_TXD_GRN	Input/Output	Host I2C data, Host UART Tx data, or calibration status	
12	H_SCL_RXD	Input	Host I2C clock, Host UART Rx data	
13	RSV	Reserved	reserved, do not connect	leave floating
14	H_SA0	Input	Host I2C Address select	Pulled low 10k ohm to ground
15	RSV	Reserved	reserved, do not connect	leave floating
16	NC		not connected	leave floating
17	NC		not connected	leave floating
18	H_NRST	Input	Reset, Active low	Pulled high 10k ohm to Vdd

Table 2-2: Module Pinout

2.3 Mechanical

2.3.1 Sensor Orientation

The module supports either the BMI088 or the LSM6DSR. The orientation shown below is the same for either sensor installed.

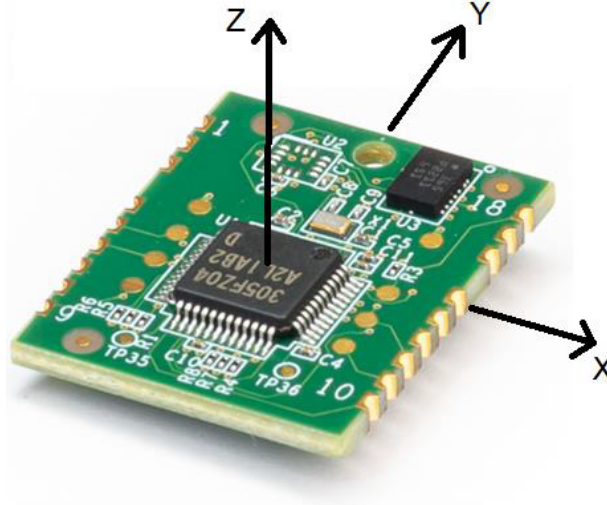

Figure 2-2: FSP201 Module Orientation

2.3.2 Module Dimensions

The FSP201 Module is 20 x 25mm, 18 castellation pins (2mm pitch).

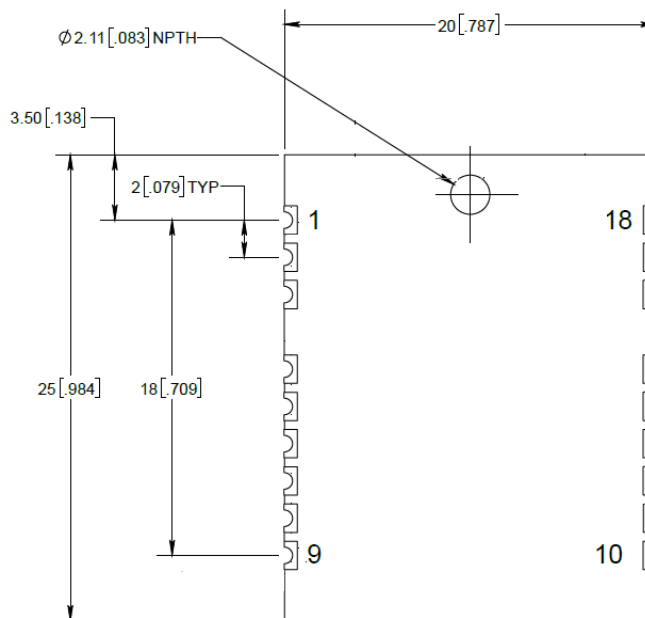

Figure 2-3: FSP201 Module Dimensions (Component side)

2.3.3 Module Recommended PCB Footprint

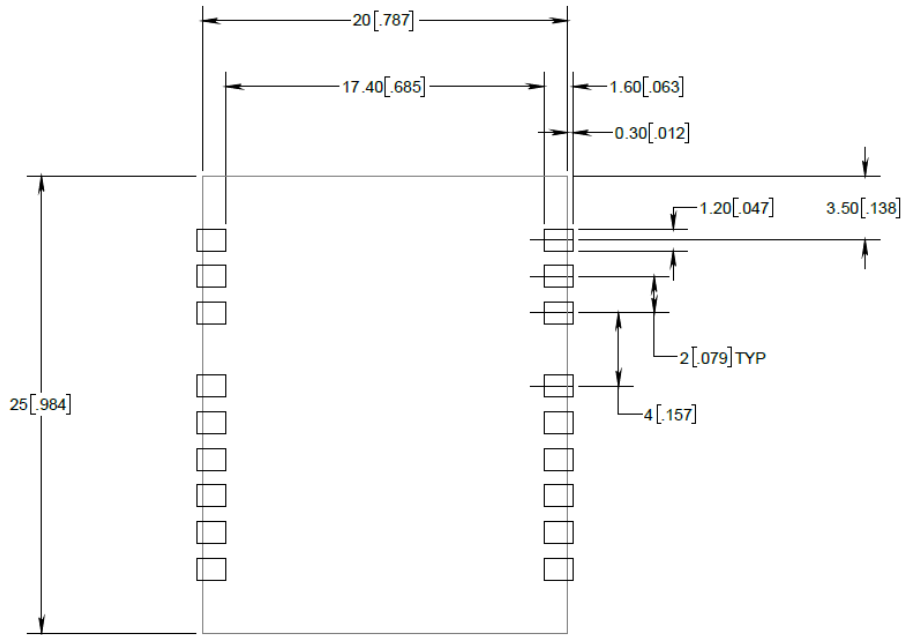

Table 2-3: FSP201 Module PCB Footprint

3. Glossary

Table 3-1 defines the acronyms used in this document.

Table 3-1: Acronyms

Term	Definition
SHTP	Sensor Hub Transport Protocol
RVC	Robot Vacuum Cleaner

USA (HQ)

15245 Shady Grove Road
Suite 400
Rockville
MD, 20850
Tel: +1 (240) 308 8328

Israel

7 Hapnina st
Raanana
4321547
Tel: +972 9 961 3700

France

Les Bureaux Green Side 5
400, Avenue Roumanille
06410 Biot
Sophia Antipolis
Tel: +33 4 83 76 06 00

Ceva China

RM1203, Building E
Chamtime Plaza Office,
Lane 2889
Jinke Road, Pudong New
District
Shanghai, 201203, China
Tel: +86-21 20577000

USA (West)

1174 Castro Street
suite 275
Mountain View
CA 94040
Tel: +1 (650) 417 7900

For more information:

