

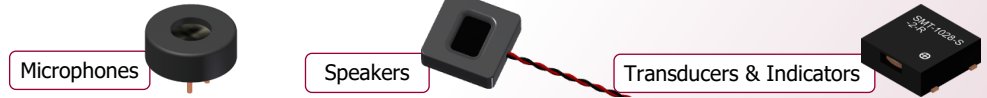

Microphones recording patient feedback, **speakers** creating tones and voice instruction, and **transducers** and **indicators** for patient and device-condition alerts, acoustic components are critical in the modern **Medical Industry**.



PUI Audio's IP67-rated Mobile Series Speakers, Surface Mount Speakers, and Surface Mount Transducers are purpose-built to serve the mobilization trend within the Medical Market.

Adapting to the Recent Changes to Audio Standards in the Medical Industry

The scope of **IEC 60601-1-8's** new audio standards for medical devices is two-fold:

1. Differentiate between devices based on their alarms so they do not sound the same, and
2. Adding harmonic content to tones that naturally direct an operator's attention to the location of the device.

These goals are designed to reduce confusion in an emergency situation and to improve an operator's reaction time to a device alarm, in the event there are many devices in a single location, such as in an emergency room.

Carefully consult the latest IEC 60601 standard as early as possible in the design cycle to find which specific audible requirements there may be for your device based on category and where it will typically be used. There might be a specific set of tones you need to reproduce and an SPL (**S**ound **P**ressure **L**evel) requirement.

How to Choose the Right Speaker for Your Application

Once the requirements are known, you can set out on selecting the acoustic component you need to use to reproduce these tones at a specific level. For many products, a speaker is required, due to the need to reproduce harmonic content. Speakers typically have a flat frequency response that allows them to play many different tones at once at relatively similar levels, where buzzers (indicators/transducers), or piezo-ceramic benders, are designed for one tone.

Choose a speaker that has a resonant frequency equal to, or below, the lowest tone you need to reproduce—in most cases that will be lower than 500 Hertz—and can easily reach your SPL requirement with the amplifier power you have available.

Both the resonant frequency and SPL are listed on each specification sheet for all PUI Audio speakers. A speaker's SPL is listed with both the input power condition and the distance at which the microphone was spaced at to capture the SPL. Many speakers, PUI Audio speakers included, are listed at 10 centimeters or 50 centimeters as there is no set standard at which distance SPL should be measured.

Basically, for each doubling of distance away from the speaker, you subtract 6 decibels. If the speaker you choose is listed as having an SPL of 86 decibels at 50 centimeters, it will output 80 decibels at 1 meter with the listed input power applied.

Increasing the input power by double (from 1 Watt to 2 Watts, for instance) nets a gain of 3 decibels, so pay attention to the speaker's power rating to ensure you are not over-driving the speaker to reach your SPL goal.

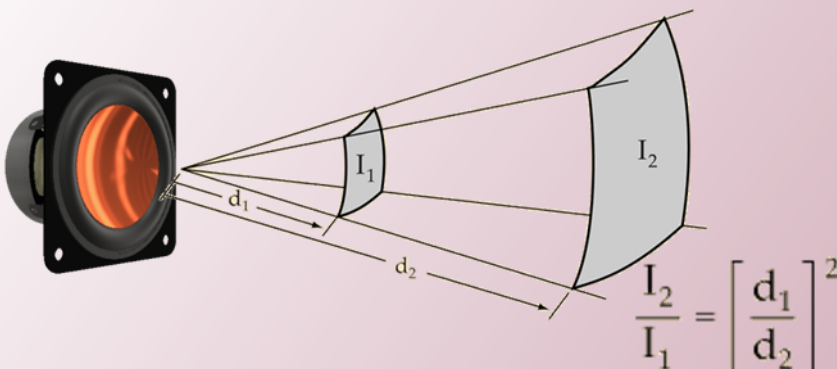

Distance	SPL	Factor	Change
10 cm	100 dB	1	-
20 cm	94 dB	2	6 dB
30 cm	90 dB	3	10 dB
50 cm	86 dB	5	14 dB
100 cm	80 dB	10	20 dB

I = Intensity/SPL, d = Distance



Interpreting a Speaker's Power Rating Correctly

All PUI Audio speakers have two power level ratings that are listed on the specifications sheet:

- A. Rated Input Power
- B. Max Input Power

Parameters	Values	Units
Rated Input Power	10	Watts
Max Input Power	20	Watts

A speaker's **rated input power** is the level at which the speaker was designed to play at continuously. A speaker's **maximum input power** is the level at which the speaker can sustain instantaneous peaks (such as with voice or music).

When using a speaker to reproduce a continuous pure tone (such as a sine wave), it is important not to exceed the rated input power. To determine how much power the speaker is dissipating, you must calculate using the peak voltage. If using a multimeter that displays RMS voltage, multiply the measurement by 1.414, square the result, and then divide by the impedance. For instance, a 2Vrms measured pure tone signal applied to an 8 ohm speaker dissipates 1 Watt of power across the voice coil.

Calculating Power to a Speaker:

$$P = \frac{(V_{RMS} * \sqrt{2})^2}{\Omega}$$

Voice and music signals are not pure power and it is ok to use the measured RMS voltage to determine the power dissipated. For instance, a 2Vrms measured signal will average about 0.5 Watts of power across the voice coil. It would still be a good idea to check the signal using an oscilloscope to ensure the peaks of the signal do not exceed the max power, though.

Selecting the Right Amplifier

One of the most common questions we are asked at PUI Audio is, "Which amplifier should I use?" Amplifier selection is pretty straight-forward as long as you pay attention to the amplifier specifications. Pay particular attention to how much power an amplifier can create with a given input voltage condition and given impedance load, while remaining under 1% THD (**T**otal **H**armonic **D**istortion).

Exceeding 1% distortion with an amplifier could drive it into a "clipping" condition that sends harmful DC voltage to a speaker, forcing it to the outer mechanical bounds and often causing a break of the leads that connect the input terminal to the voice coil. It is possible to damage a speaker rated for 5 Watts with a 4 Watt clipped signal. PUI Audio recommends selecting an amplifier that has double the power capacity of what you need.

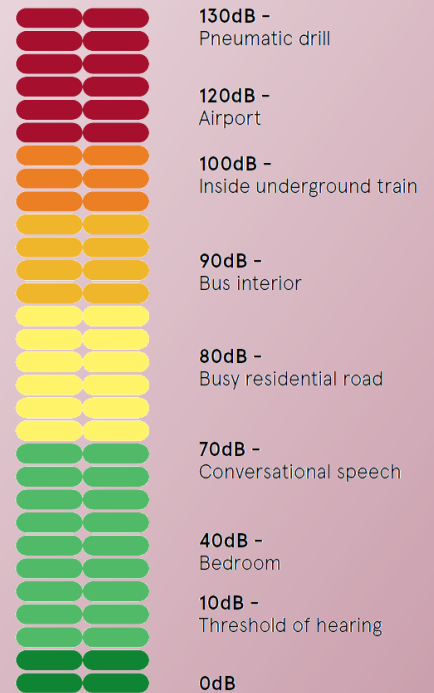
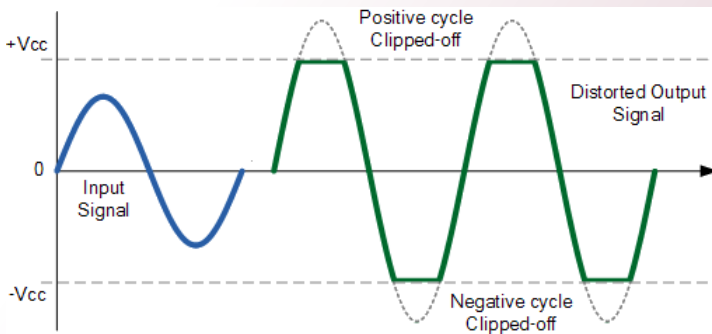

Consider Your Environment

Despite choosing the correct speaker with the needed parameters, low perceived sound can still occur. A common reason for that is that the ambient sound levels where the product is deployed were not considered.

- Invest in a low cost SPL meter, or download an SPL app for your smartphone
- Take multiple measurements of the environment
- Build a use-case to determine the distance between your product and the target audience
- Target a value of about 15 dB to 20 dB over ambient SPL for your product to be discernable, at the appropriate distance.

Sound pressure level

PUI Audio's knowledge and expertise has led to relationships with Medtech companies that have lasted for decades. From concept to production, Medical engineers rely on our ability to 3D model and rapid prototype, as well as our professional customer service. PUI Audio is the acoustic component partner you can trust.